

**AUTOMATIC SELF
CLEANING SCREEN
FILTER VERTICAL**

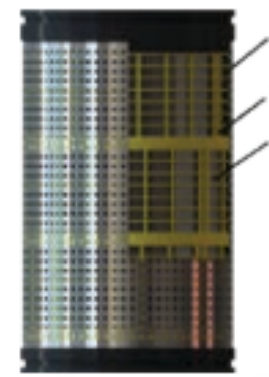

1 - Protector coarse screen SS304L
2 - Molded plastic rib (PA6)
3 - The main filtering screen

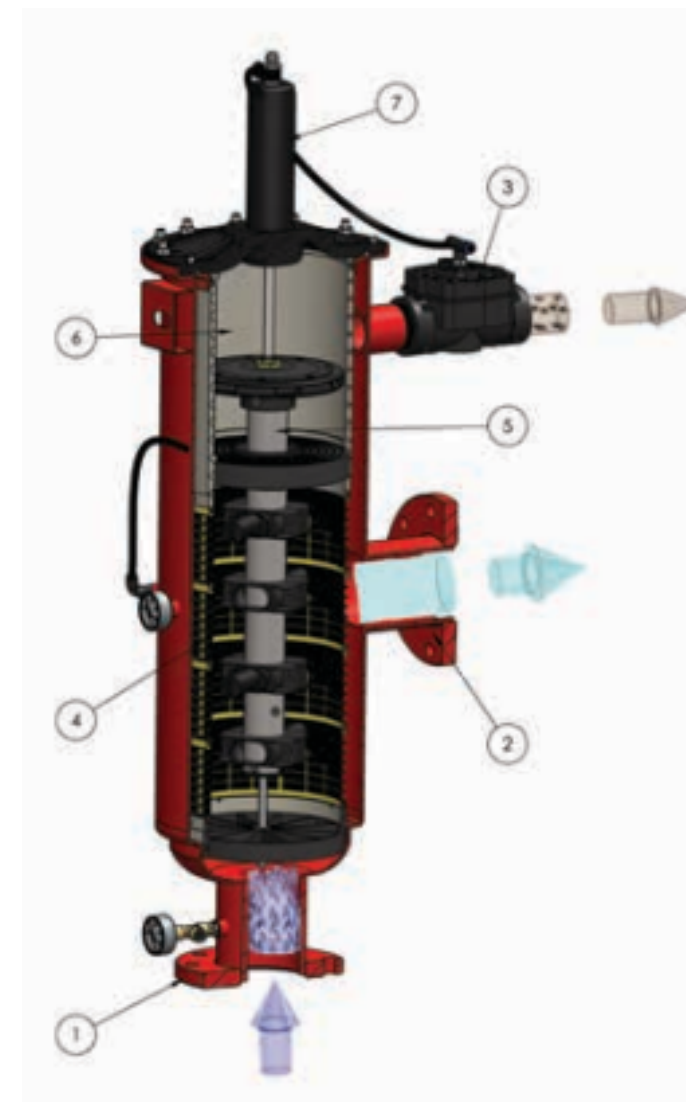
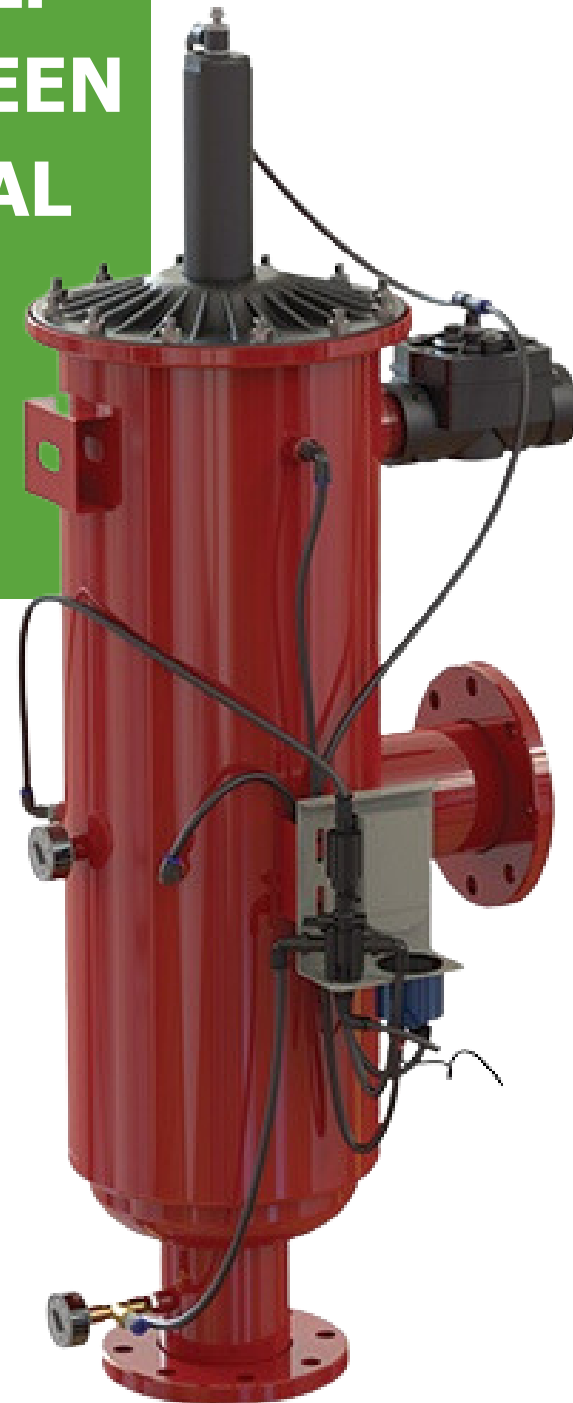
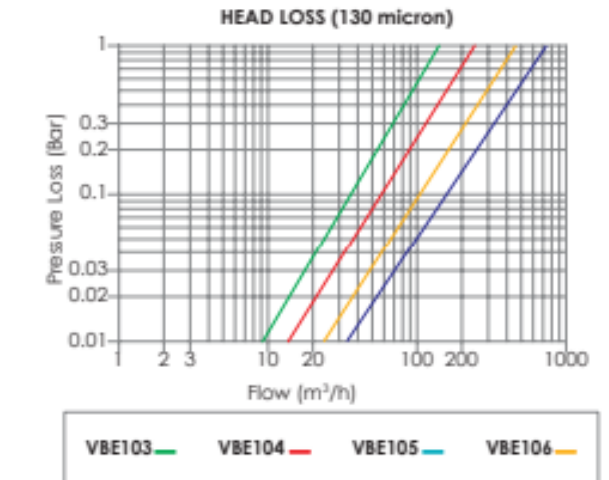
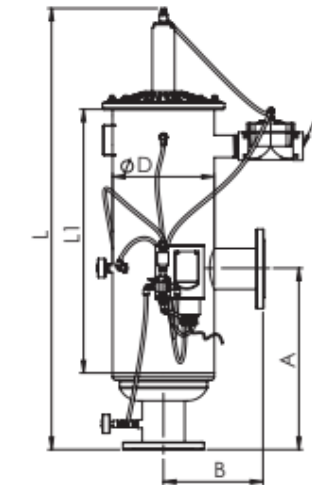
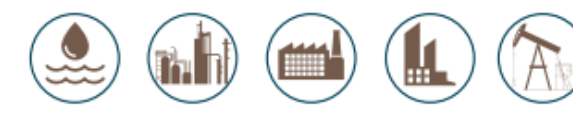

Inlet/Outlet		A	B	L1	L	D	F	Drain Flow Rate		Main Flow Rate		Filtration Area
inch	DN	mm				inch		L/S	Usgpm	m³/h	Usgpm	cm²
2	50	465	270	515	965	10	1 ½	3,3	53	30	132	1317
2	50	515	270	615	1065	10	1 ½	5	79	45	198	1975
2½	65	465	270	515	965	10	1 ½	3,3	53	40	176	1317
2½	65	515	270	615	1065	10	1 ½	5	79	50	220	1975
3	80	465	270	515	965	10	1 ½	3,3	53	55	242	1317
3	80	515	270	615	1065	10	1 ½	5	79	70	308	1975
4	100	515	270	615	1065	10	1 ½	5	79	100	440	1975
4	100	565	270	715	1165	10	2	6,7	105	120	528	2634
4	100	855	287	1120	1725	10	2	5	79	140	616	3951
5	125	855	287	1120	1725	10	2	5	79	150	660	3951
5	125	955	287	1320	1925	10	2	6,7	105	160	704	5268
6	150	955	287	1320	1925	10	2	6,7	105	180	792	5268

Working principle

Filter sections; 1- Dirty water inlet, 2-Clean water outlet, 3- Backwash dirty water outlet drainage, 4-Sieve internal kit (multilayer), 5-Collector kit (backwash water vacuuming channel), 6-Turbine chamber, Water enters the filter and passes through multi-layer filter, then passes coarse sieve. Water continues to flow from fine filter to exit, creates a layer of pollution inner surface of the filter and this pollution creates pressure difference at inlet and outlet of the filter. Backwash begins when this pressure difference comes at a predetermined level. A specified pressure difference is reached, the backwash control unit opens discharge valve. Atmospheric pressure in discharge pipe creates a strong backwash. This flow returns cleaning collector through hydraulic turbine and drainage pipe after vacuuming the pollution in the inner surface of filter by creating a vacuum effect at nozzles. Pressure decrease consist in turbine part and piston drainage provides a linear motion to cleaning collector. This rotation and linear motion provides absorption of pollution layer in the inner surface of filter by nozzles. When process is completed, cleaning collector automatically makes a second backwash and returns to its original position, so backwashing process is completed. During backwash filtering process continues. For efficiently work of system, during backwash process inlet pressure must not be less than 2 Bar (29PSI).

GENERAL CHARACTERISTICS

- Body Material: S195T / SS 316L / SS 304 L
- Screen Material: SS 304L, PA6GFR30
- Maximum Working Pressure : 10 Bar (145 PSI)
- Minimum Working Pressure: 2 Bar (29 PSI)
- Maximum Working Temperature: 60 °C (140 °F)
- Back Flush Operation Criteria: Time and / or Pressure Differential
- Back Flush Controlling Unit: Electronic (AC/DC) Control
- Filtration Degree: 20-2000 micron (μ)
- Painting Method: Electrostratic Powder Coating
- Painting Material: Epoxy Polyester